

PD Solution for Fast Charge Application

1. General Description

The SW3526 is a highly integrated power management IC for fast charge application, and supports Type-C or Type-A port output. It integrates 3.5A synchronous buck, PPS/ PD/ QC/ AFC/ FCP/ SCP/ PE/SFCP fast charge protocol, CC/CV mode. With simple external components, The SW3526 provides a turn-key high efficiency solution for fast charge application.

2. Applications

- Car Charger
- Adapter

3. Features

- **Synchronous Buck**
 - Current up to 3.5A
 - Input Voltage 6~35V
 - Support CC/CV Mode
 - Support Wire Drop Compensation
- **Output Fast Charge Protocol**
 - Support PPS/PD3.0/PD2.0
 - Support QC4+/QC4/QC3.0/QC2.0
 - Support AFC
 - Support FCP
 - Support Low Voltage/High Voltage SCP
 - Support PE2.0/PE1.1
 - Support SFCP
- **Type-C Interface**
 - Support USB Type-C Specification
 - Support DFP Role
- **BC1.2 Module**
 - Support BC1.2 DCP
 - Support Apple & Samsung Device
- **Fast Charge LED**
 - Support Fast Charge LED Driver
- **Protection**
 - Softstart
 - Input Over Voltage Protection
 - Input Under Voltage Protection
 - Output Over Current Protection
 - Output Short Protection
 - Over Temperature Protection
- **I2C Interface**
- **QFN-24(4x4mm) Package**

4. Functional Block Diagram

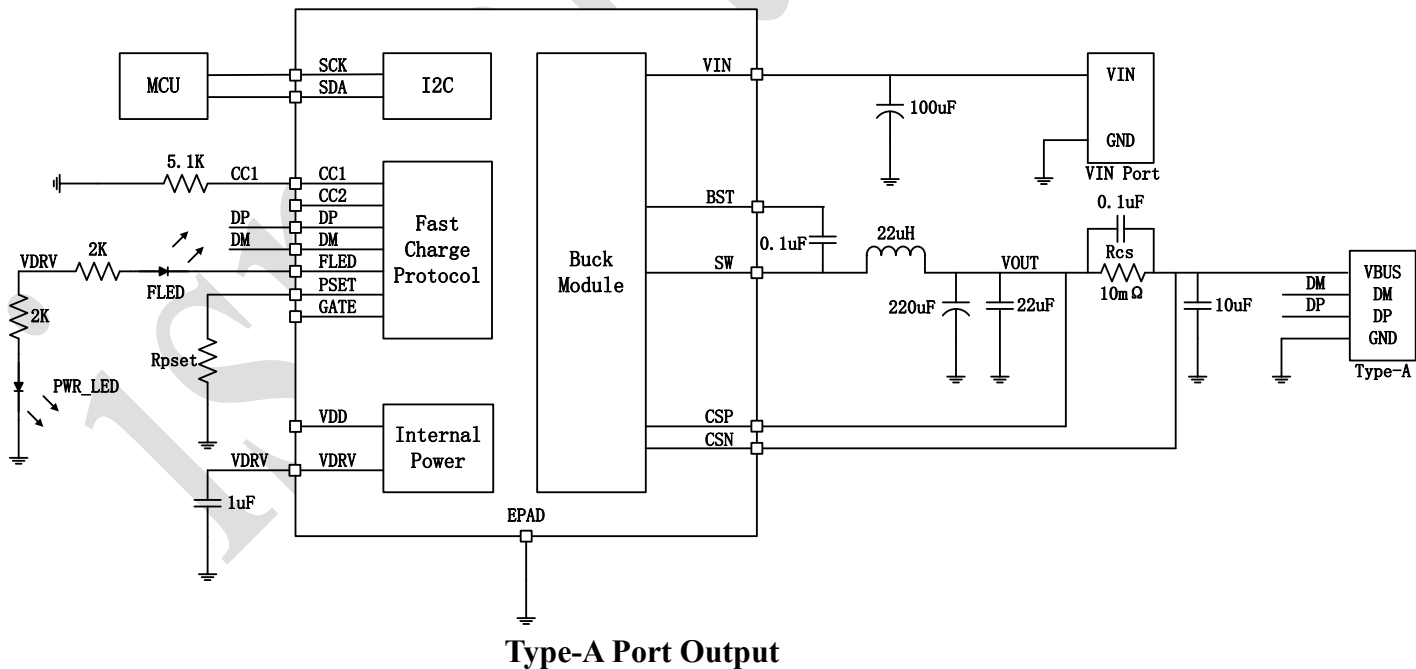
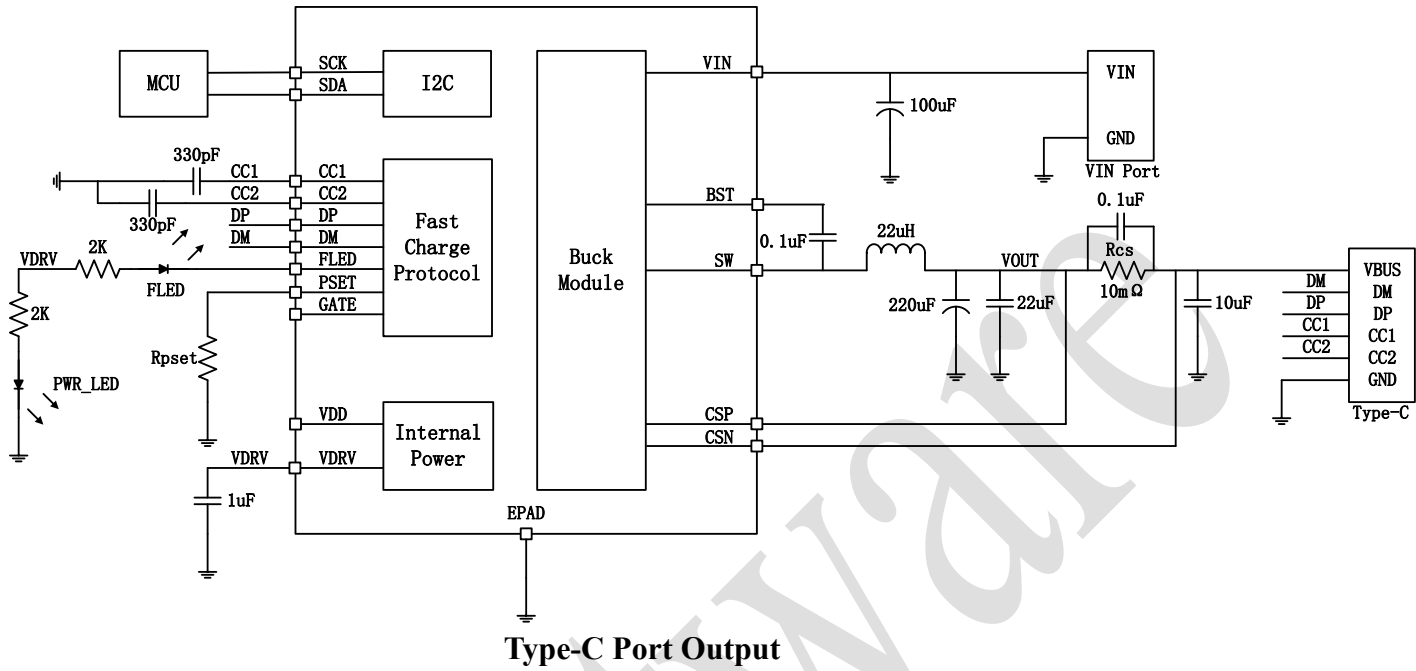

5. Pin Configuration and Function

5.1. Pin Configuration

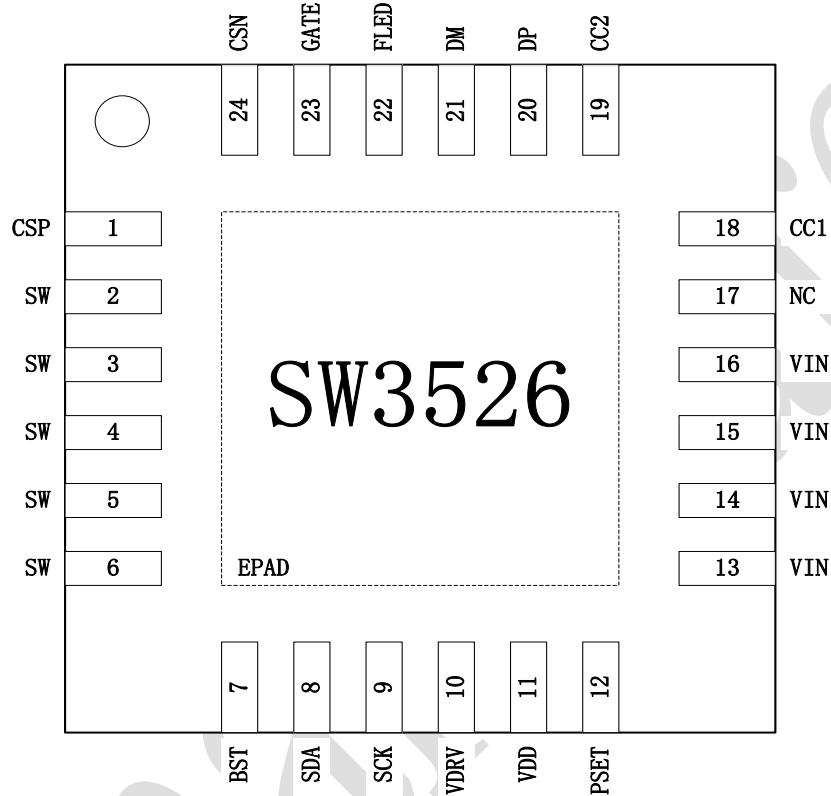

5.2. Pin Descriptions

Pin	Name	Function Description
1	CSP	Current sense positive/voltage sense pin.
2, 3, 4, 5, 6	SW	Switching node.
7	BST	Bootstrap pin for high side NMOS.
8	SDA	I2c data.
9	SCK	I2c clock.
10	VDRV	Driver power, connect a 1uF ceramic capacitor to ground, and external device such as mcu can power from this pin.
11	VDD	Internal power, do not connect ceramic capacitor and power external device from this pin.
12	PSET	Output power set pin, connect a 1% accuracy resistor to ground to configure output power, do not float.
13, 14, 15, 16	VIN	Input power.

17	NC	Floating.
18	CC1	Type-C port configure channel CC1.
19	CC2	Type-C port configure channel CC2.
20	DP	Type-C port DP pin.
21	DM	Type-C port DM pin.
22	FLED	Fast charge led driver.
23	GATE	Power path control pin.
24	CSN	Current sense negative pin.
	EPAD	Exposed pad.

6. Absolute Maximum Ratings

Parameters	Symbol	MIN	MAX	UNIT
Input Voltage	VIN	-0.3	35	V
Output Voltage	CSP/CSN	-0.3	22	V
SW Voltage	SW	-0.3	35	V
BST Voltage	BST-SW	-0.3	6	V
Power Path Control Voltage	GATE	-0.3	27	V
CC1/CC2/DP/DM Voltage	CC1/CC2/DP/DM	-0.3	25	V
Other Pin Voltage		-0.3	6	V
Junction Temperature		-40	+150	°C
Storage Temperature Range		-60	+150	°C
ESD (HBM)		-4	+4	KV

【 Notice 】 Stresses beyond those listed under absolute maximum ratings may cause permanent damage to the device. These are stress ratings only, and functional operation of the device at these or any other conditions beyond those indicated under recommended operating conditions is not implied. Exposure to absolute-maximum-rated conditions for extended periods may affect device reliability.

7. Recommended Operating Conditions

Parameters	Symbol	MIN	Typical	MAX	UNIT
Input Voltage	VIN	5		32	V

8. Electrical Characteristics

($V_{IN} = 12V$, $T_A = 25^{\circ}C$, unless otherwise specified.)

Parameters	Symbol	Test Conditions	MIN	TYP	MAX	UNIT
Power Supply						

VIN Input Voltage	V_{IN}		5		32	V
VIN Input UVLO Threshold	V_{IN_UVLO}	VIN Voltage Falling	5.2	5.3	5.4	V
VIN Input UVLO Hysteresis	$V_{IN_UVLO_HYS}$	VIN Voltage Rising	0.4	0.6	0.8	V
VIN Input OVP Threshold	V_{IN_OVP}	VIN Voltage Rising	29.6	30.8	32	V
VIN Input OVP Hysteresis	$V_{IN_OVP_HYS}$	VIN Voltage Falling	0.4	0.8	1.2	V
VDRV Output Voltage	V_{DRV}	$V_{IN}=12V$	4.9	5	5.1	V
VDRV Output current	I_{DRV}	$V_{IN}=12V$		50		mA
VDD Output Voltage	V_{DD}	$V_{IN}=12V$	4.9	5	5.1	V
Quiescent Current	I_Q	$V_{IN}=12V, I_{OUT}=0mA$		2	4	mA
Synchronous Buck						
Switching Frequency	F_{CHG}		110	125	140	KHz
Output Voltage	V_{OUT}	$V_{OUT}=5V$	5.0	5.1	5.2	V
		$V_{OUT}=9V$	8.9	9.1	9.3	V
		$V_{OUT}=12V$	11.9	12.1	12.3	V
		$V_{OUT}=15V$	14.8	15.1	15.4	V
		$V_{OUT}=20V$	19.8	20.1	20.4	V
CC Current Limited	I_{CC}	$R_{CS}=10m\Omega$	3.0	3.3	3.6	A
Wire Drop Compensation	V_{OUT_WDC}	$R_{CS}=10m\Omega$			200	mV
High Side NMOS	R_{DSON_H}		28	30	34	m Ω
Low Side NMOS	R_{DSON_L}		18	20	24	m Ω
Type-C						
CC Current Source	I_{CC_SOURCE}	Power Level=3.0A	310	330	350	uA
BC1.2						
DP/DM Voltage	DP	Apple 2.4A Mode	2.55	2.7	2.85	V
	DM	Apple 2.4A Mode	2.55	2.7	2.85	V
PE						
Current Threshold	I_{REF}		150	250	350	mA
Quit Time	t_{PLUG_OUT}		160	200	240	mS
I2C						
Rate	f_{CLK}			100	400	Kbit/S
Thermal Shutdown						

Thermal Shutdown Threshold	T _{SHDT}	Temperature Rising	135	150	165	°C
Thermal Shutdown Hysteresis	T _{SHDT_HYS}	Temperature Falling	35	50	65	°C

9. Functional Description

9.1. Synchronous Buck

The SW3526 integrates a high efficiency synchronous buck with inner NMOS and output current up to 3.5A and efficiency up to 94%(VIN=12V, VOUT=5V, IOU=3A).

The synchronous buck works in PSM/PWM mode with switching frequency of 125KHz. It works in PSM mode when in light load and in PWM mode in heavy load to make a better efficiency. It will automatically change in these two modes base on output current.

The synchronous buck supports CC/CV mode. When output current is lower than CC limited current, output voltage will keep constant. When output current reaches CC limited current, output voltage will drop to keep output current constant.

The synchronous buck supports wire drop compensation. Output voltage will linear increase according to output current and the maximum increased voltage is limited to 200mV.

The synchronous buck integrates input over voltage, input under voltage, output over current and short protection.

9.2. Power Configuration

The SW3526 supports output power configuration, and sets output power with a resister from PSET Pin to ground.

Resister	Output power
0	18W
3.9K	24W
9.1K	30W
16K	45W
24K	60W

33K	65W
-----	-----

9.3. Type C Interface

The SW3526 integrates Type-C logic controller and supports DFP/SOURCE role. When UFP is attached, Type-C port will automatically turn on to supply device. When UFP is detached, Type-C port will automatically turn off.

When SINK is attached and Type-C port turns on , the SW3526 will broadcast power level of 3A.

When CC1 is connected a 5.1K resistor to ground, the SW3526 works as Type-A port.

9.4. PD Fast Charge

The SW3526 integrates PPS/PD3.0/PD2.0 fast charge protocol. PPS supports 3.3~21V@3A output voltage. PD3.0/PD2.0 supports 5V/9V/12V/15V@3A.

9.5. QC Fast Charge

The SW3526 integrates QC4+/QC4/QC3.0/QC2.0 fast charge protocol. It supports Class A/Class B, while QC2.0 supporting 5V/9V/12V/20V output voltage and QC3.0 supporting 3.6V~20V output voltage, 200mV/Step.

QC2.0/QC3.0 will output voltage base on DP/DM voltage:

Device		SW3526	
DP	DM	VOUT	Note
3.3V	3.3V	20V	
0.6V	0.6V	12V	
3.3V	0.6V	9V	
0.6V	3.3V	continuous mode	0.2V/Step
0.6V	GND	5V	

9.6. AFC Fast Charge

The SW3526 integrates AFC fast charge protocol, and supports 5V/9V/12V output voltage.

9.7. FCP Fast Charge

The SW3526 integrates FCP fast charge protocol, and supports 5V/9V/12V output voltage.

9.8. SCP Fast Charge

The SW3526 integrates SCP fast charge protocol, and supports 5V@3.5A low voltage SCP and 10V@2A high voltage SCP.

9.9. PE Fast Charge

The SW3526 integrates PE2.0/PE1.1 fast charge protocol. PE1.1 supports 5V/7V/9V/12V output voltage. PE2.0 supports 5V~12V output voltage, 500mV/Step.

9.10. SFCP Fast Charge

The SW3526 integrates SFCP fast charge protocol, and supports 5V/9V/12V output voltage.

9.11. BC1.2 Module

The SW3526 integrates BC1.2 controller, and automatically detects apple and samsung devices:

Apple 2.4A mode: DP=2.7V, DM=2.7V;

Samsung 2A mode: DP=1.2V, DM=1.2V;

9.12. Fast Charge Led

The SW3526 integrates fast charge LED driver through FLED pin. FLED pin will drive low to turn on

fast charge led in fast charge status.

9.13. ADC

The SW3526 integrates 12 bit ADC, and samples input voltage/output voltage/output current.

ADC channel	Range	Step
Input voltage	0~40.96V	10mV
Output voltage	0~24.576V	6mV
Output current	0~6.4A	1.5625mA

9.14. I2C Interface

The SW3526 integrates I2C interface, and supports 100K/400K rate.

Read Timing:

Slave address : 0x3C

Register address: 0xB0

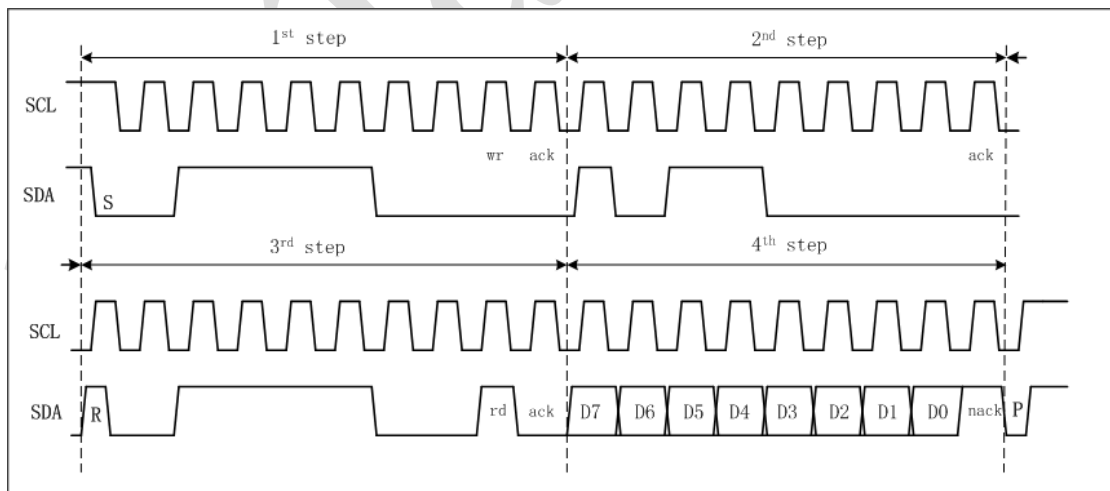

Write Timing:

Slave address : 0x3C

Register address: 0xB0

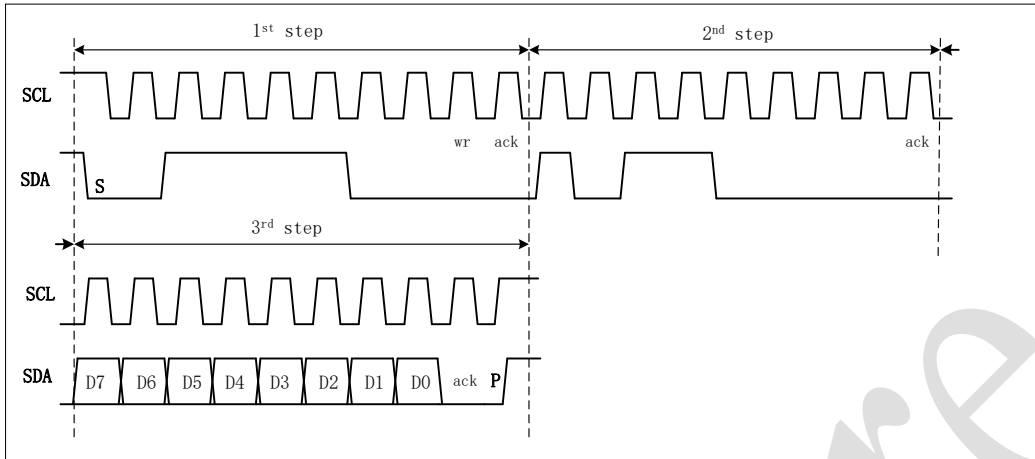

10. Typical Application Circuits

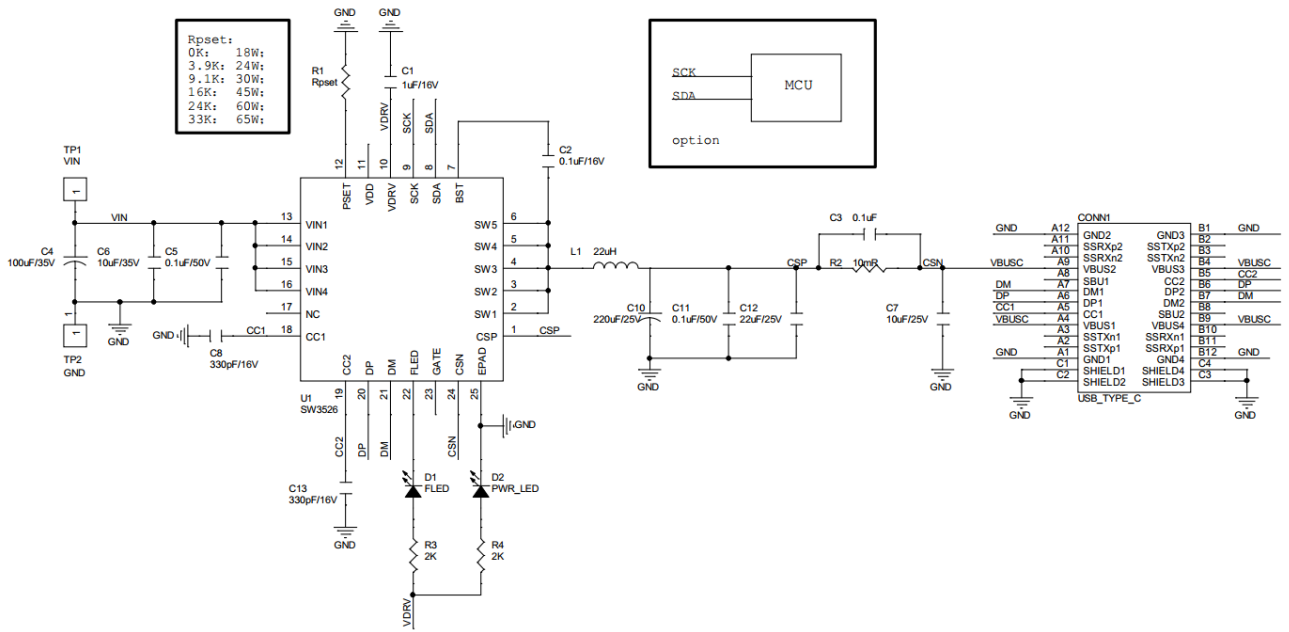

Type-C Port Output Application

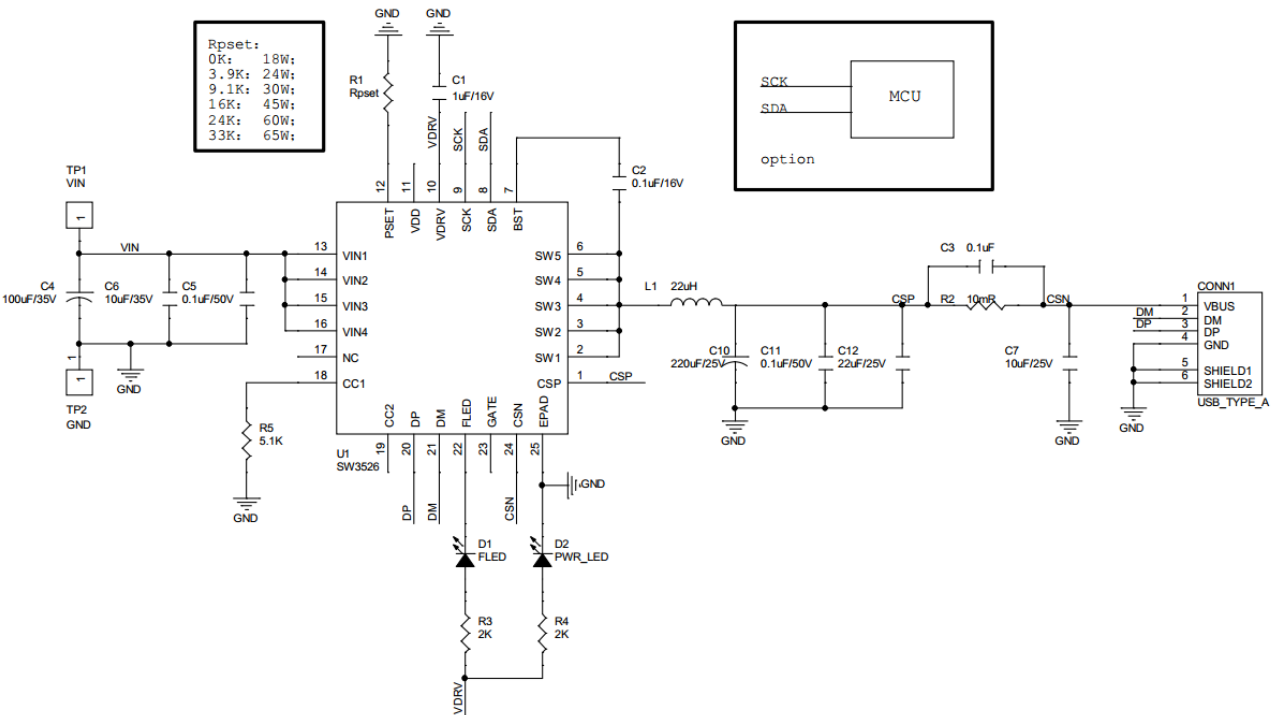

Type-A Port Output Application

11. Mechanical and Packaging

11.1. Package Summary

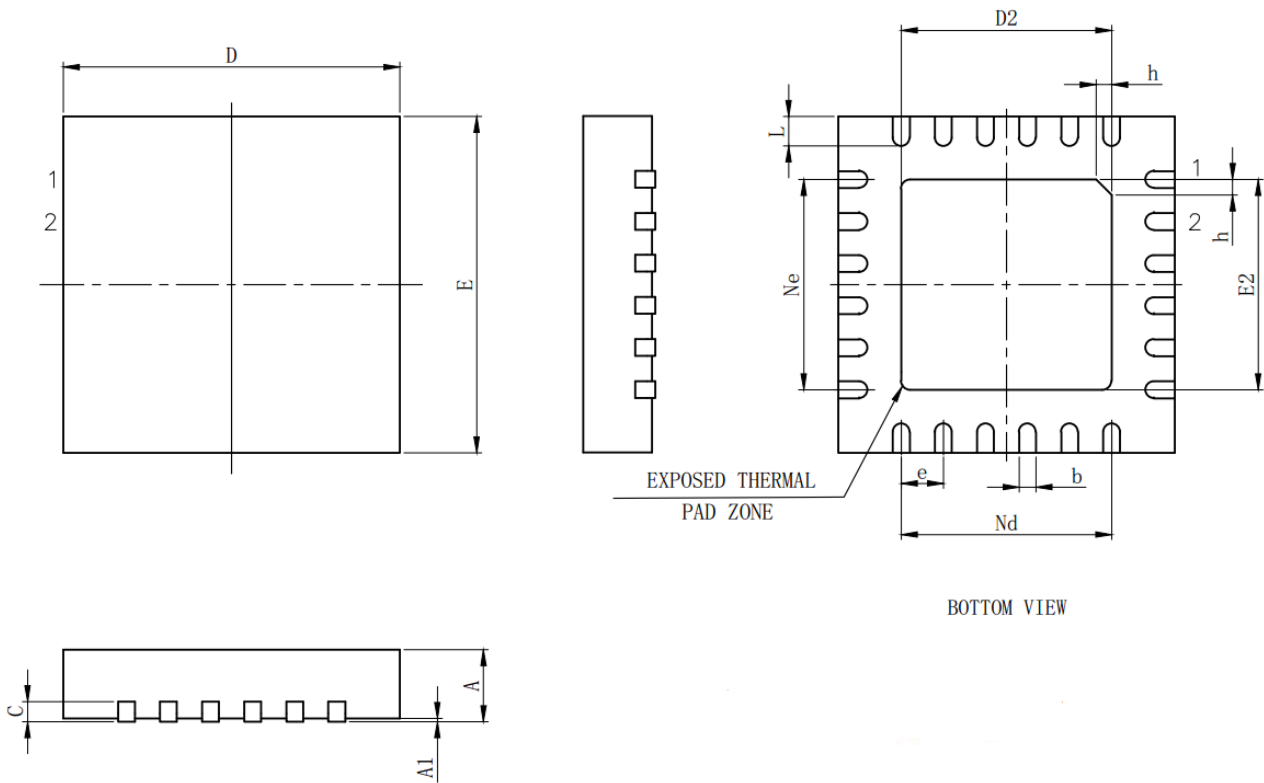

11.2. Package Outline and Dimensions

Symbol	Dimension in Millimeters		
	MIN	NOM	MAX
A	0.70	0.75	0.80
A1	0	0.02	0.05
b	0.18	0.25	0.30
c	0.18	0.20	0.25
D	3.90	4.00	4.10
D2	2.40	2.50	2.60
e	0.50BSC		
Ne	2.50BSC		
Nd	2.50BSC		
E	3.90	4.00	4.10
E2	2.40	2.50	2.60
L	0.35	0.40	0.45
h	0.30	0.35	0.40

12. Revision History

- V1.0 Initial version.
- V1.1 Add drain-source on resistance of power MOS.
- V1.2 Modify company logo.
- V1.3 Update document template.

Disclaimer

Zhuhai iSmartWare Technology Co., Ltd. (hereinafter referred to as "iSmartWare") may modify or update the products, services and this document provided at any time without prior notice. Customers should obtain the latest relevant information before placing an order and confirm that such information is complete and up-to-date.

The information contained in this document is for your convenience only, and iSmartWare makes no representations or warranties, express or implied, written or oral, statutory or otherwise, for such information, including but not limited to the purpose, characteristics, conditions of use, merchantability of the product. etc. iSmartWare does not assume any responsibility for this information and the consequences caused by the unreasonable use of this information.

iSmartWare assumes no obligation for application assistance or customer product design. Customers are solely responsible for their products and applications using iSmartWare. Customers should provide sufficient design and operation security verification, and guarantee that when integrating iSmartWare products into any application, they will not infringe third-party intellectual property rights, and iSmartWare will not be responsible for any infringements.

When resale of iSmartWare products, if there are differences or false components compared with the product parameters and their statements, all express or implied authorizations of iSmartWare related products will be automatically lost, and this is unfair and fraudulent. For business behavior, iSmartWare reserves the right to protect its rights in all legal ways. iSmartWare assumes no responsibility or liability for any such misrepresentation.

This document is only allowed to be reproduced without any tampering with the content and with relevant authorizations, conditions, restrictions and statements, otherwise iSmartWare has the right to pursue its legal responsibility. iSmartWare assumes no responsibility or liability for such tampered documents. Reproduction of information involving third parties is subject to additional restrictions.